

# Installation instructions

FMC920  
Tracker



Applies to services:



Car Assistant



Pins



Fleet Manager Fleet



Fleet Manager Basic



Treesat



## WARNINGS

Please read this manual before proceeding with the installation. All connection activities should be performed with extreme caution. For safety reasons, the module should be installed by qualified specialists.

## DESCRIPTION

The kit consists of a small electronic device and a mobile or web application. The communication module is mounted in the vehicle. The communication module monitors the GPS position in real time with GNSS and GSM connectivity, collects device coordinates and other useful data and sends them via the GSM network to the server. Communication with the server and the application via the mobile network means that the user receives a number of functions, e.g. a theft alarm with a map or an accident detection system informing about a possible collision. The map and navigation will also help you find a vehicle left in a parking lot or in a foreign city. There is also an ignition lock function. Detailed functionalities of individual products can be found at [treesat.io](https://treesat.io).

The device is ideal for applications where location acquisition of distant objects is required. It can be used by companies with a car fleet, car rental companies, taxi companies, and ordinary users using their own passenger cars.

## MOUNTING THE DEVICE IN THE VEHICLE

When mounting the device in a vehicle, remember to avoid sensitive places that may suppress the GSM and GPS signal. The best place to mount the device is its installation under elements made of plastic, e.g.: upholstery, post, etc. The recommended, exemplary location of the device is shown in the figure below.

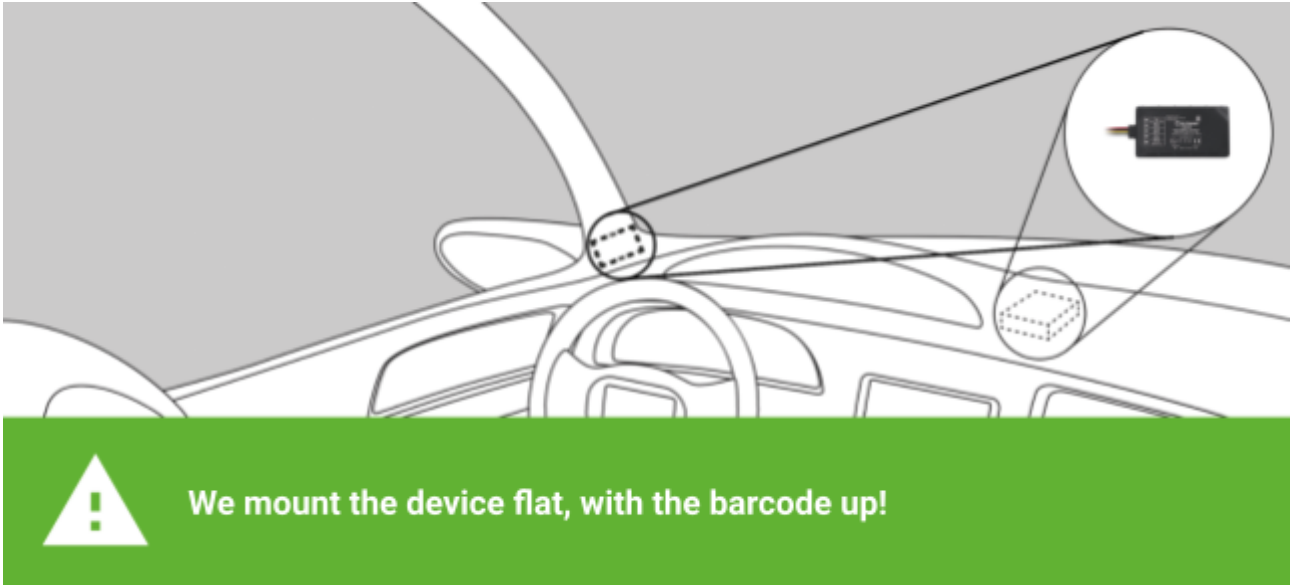

## CONNECTION AND WIRE DESCRIPTION

Color	Destiny	Installation tips
Red	Powering the device	Connect to a permanent 10-30V DC power supply
Black	Device weight	Connect to ground
Yellow	Ignition switch (DIN1)	Ignition signal (not lost during start-up)
Gray	AIN1	Voltage input 0-30V DC (connect plus from alarm siren)
White	DOUT1	(locking/unlocking) Normal Open, ground control, max. 0.5A DC

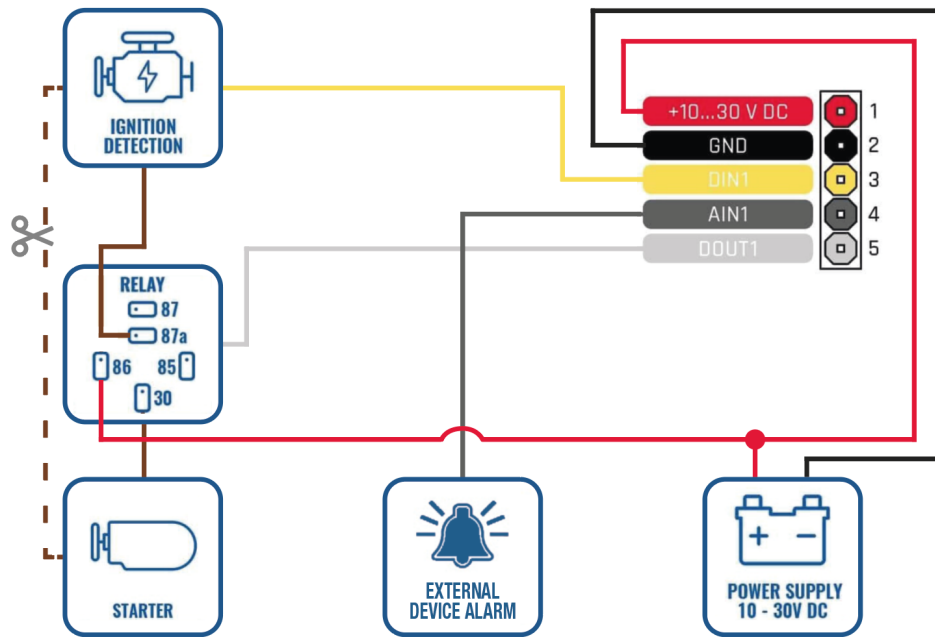

## IGNITION CUT-OFF CONNECTION DIAGRAM

Remote ignition cut-off is only possible for Car Assistant services



To be sure of operation, perform a function test "Ignition cut off" in the mobile application.

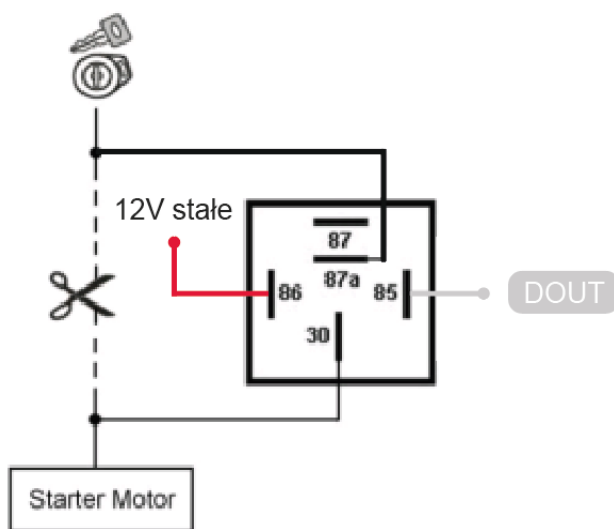

Connection in the car

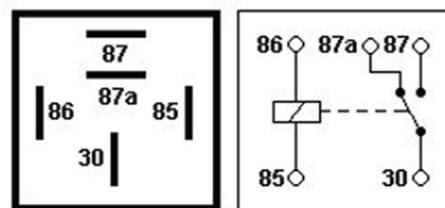

Relay pin description

## OPERATION CHECK

After connecting the device, check its correct operation by observing the diodes.

Behavior of the “Status” LED (GSM):

- The LED blinks every second – normal operation, GSM signal has been stabilized.
- LED flashes every two seconds – GSM is in deep sleep mode.
- The LED flashes quickly for a short time – GSM is sending data to the server.
- Constant flashing of the diode – the device is being updated.
- The LED is off – faulty GSM modem.

Behavior of the “Navigate” LED (GPS):

- LED flashes every second – normal operation, GPS signal has been stabilized.
- The LED is not lit at all – the GPS module is turned off, the GPS is in deep sleep or the GPS antenna has a short circuit.
- The LED is lit continuously – no GPS signal, the module is searching for satellites.

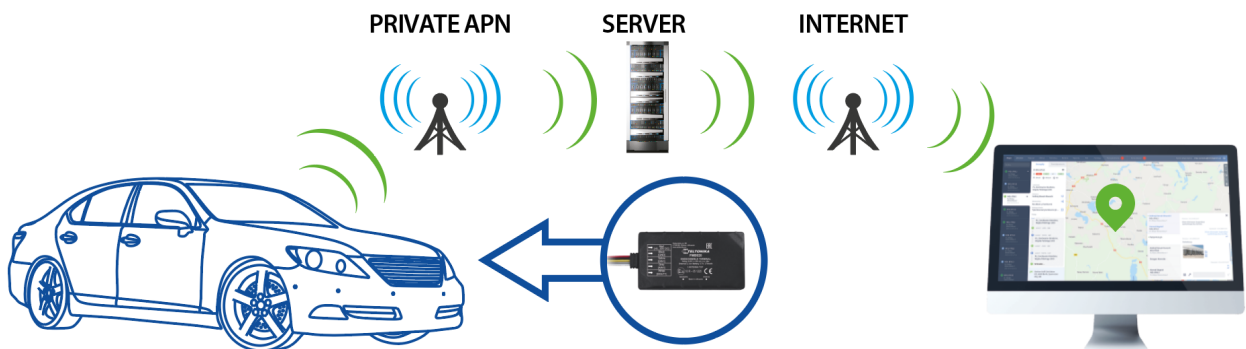

## START PINS

1. Download the application on your phone, create an account, then log in.
2. Add the car (device) to your account in the app. The serial number is located **on the device, below the barcode** .
3. It may take up to 24 hours for your device to activate. Using the user manual, install the device in the vehicle after receiving a notification in the application about the activation of the SIM card.

## STARTING CAR ASSISTANT

1. Download the application on your phone, create an account, then log in.
2. Add the car (device) to your account in the app. The serial number is located **on the device, below the barcode**.
3. It may take up to 24 hours for your device to activate. Using the user manual, install the device in the vehicle after receiving a notification in the application about the activation of the SIM card.
4. Check the operation of the device by arming and triggering an alarm in the application. The device is ready for operation.
5. If the functional test did not take place under the target account in the application (fitter test account), then Delete the vehicle (device) from the test account: go to Vehicle details > click on the Settings icon (gear in the upper right corner) > click on Delete vehicle. All data will be erased. Then add the device to your customer account again.

## STARTING FLEET MANAGER

1. Using the manual, install the device in the vehicle. Your device is already active.
2. Log in to the Web application – you will receive login details by e-mail.
3. The device has been added to your account by Treesat. Create a vehicle in the system and assign the number of the mounted device. Your devices are in the drop-down list.

## TECHNICAL SPECIFICATIONS

### GSM

- 2G/4G: B2, B3, B5, B7, B8, B20, B28
- LTE Cat 1

### interface

- 1 digital input, 1 analog input
- 1 digital output NO
- accelerometer
- Internal high-gain GSM antenna
- Internal high-gain GNSS antenna
- 2 device status LEDs
- Operating temperature: -20 °C to +40 °C
- Humidity: 5% to 95%
- IP54
- Dimensions: L(79mm) x W(43mm) x H(12mm)

### GNSS

- GPS, GLONASS, GALILEO, BEIDOU, SBAS, QZSS, DGPS, AGPS
- Tracking: 33 channels
- Sensitivity -165 dBM
- Hot start <1s
- warm start <25s
- Cold start <35s
- Accuracy <3m

### Power

- Power supply 10~30V DC, 1A Max.
- Integrated backup battery: 170 mAh Li-Ion 3.7 V (0.63 Wh)
- Current consumption at 12V DC
- Sleep: <3mA
- Nominal operation: <28mA

## SIGNS



CE mark. This marking informs that the device complies with the terms of Directive 2014/30/EU regarding the compliance of Member States with electromagnetic compatibility regulations and the terms of Directive 2014/35/EU regarding compliance by Member States with low voltage regulations and safety related to the operation of electrical equipment.



The symbol of the crossed-out waste bin attached to the product means that the product is covered by the European Directive 2012/19/EU. Information on separate collection points for waste electrical and electronic products can be obtained from the place of residence. Please follow the guidelines of your local authorities and do not dispose of this type of equipment with other household waste. The correct disposal of your old products helps prevent environmental pollution and loss of health.



If this logo is found on the product, it means that the fees related to the appropriate recycling and recovery system have been paid.



This logo informs that the device is compliant with the terms of Directive 2011/65/EU (commonly known as the Restriction of Hazardous Substances Directive or RoHS). The RoHS Directive covers restrictions at the production stage on the introduction of hazardous substances in electronics.

## CONTACT DETAILS



**Treesat sp. z o.o**

Wędkarska 38b

10-180 Olsztyn

[pomoc@treesat.io](mailto:pomoc@treesat.io)

+48 89 888 10 16

[treesat.io](http://treesat.io)